



JIEHUANG CHIYANG



JIEHUANG CHIYANG

NINGBO JIEHUANG CHIYANG ELECTRONIC TECH CO.,LTD

One stop Metal Parts Solution Provider

Jiehuang Overview

NINGBO JIEHUANG CHIYANG Electronic Tech Co., Ltd. is a technology-oriented company affiliated to JIEHUANG Group, and engaged in R&D, production and sale of connector ,we have **PM and MIM products and Die casting products(Alumimin and Znic Alloy)** ,3 factories, Our products are mainly applied to 3C (Computer, Communication, Consumer Electronics) sectors Auto parts, and Industry parts.

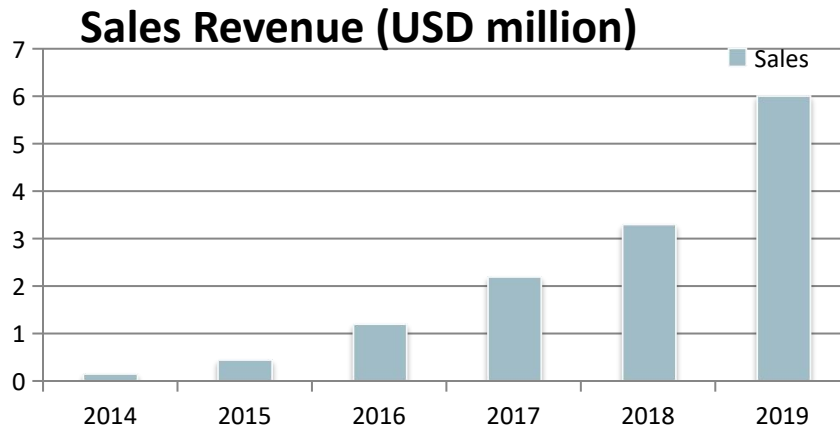

➤ **220+** employees, **20+** R&D engineers ,and **30+** QC workers

➤ **8** experts

➤ **28000+** square meters facilities

Factory	Square Meters	Manufactruer Line	Workers	R&D engineers	QA
MIM	12000	14	72	8	10
PM	6000	12	64	6	10
Die-casting	10000	10	86	7	11



Content



- 01 **Company Overview**
- 02 **Factories view**
- 03 **Products**

Organizational Structure

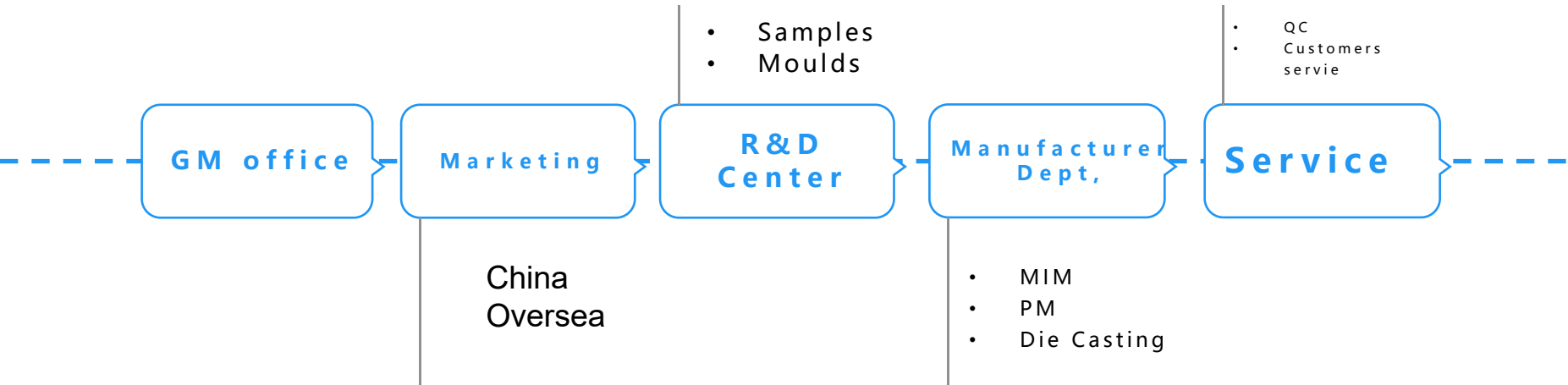

Road Map

2006

Kunshan Jiehuang
Established

MIM



2009

Ningbo Jiehuang
Chiyang Established

MIM



2015

Ningbo Chiyang
Factory Established

PM



2019

Shareholder of Ningbo
JinYao Yutong Auto

Die Casting





Content



- 01 **Company Overview**
- 02 **Factories view**
- 03 Products

MIM FACTORY



Mould-Toolings



Swiss Agie Charmilles EDM

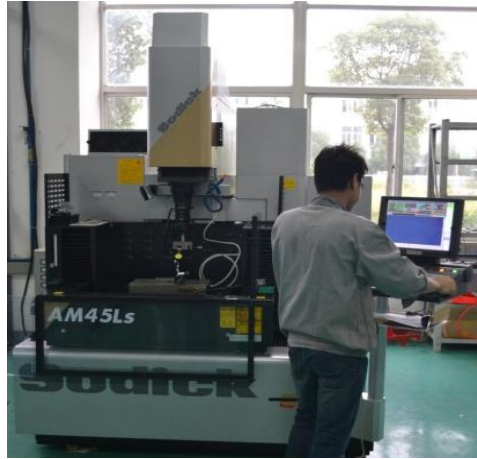

Sodick EDM



FANUC CNC



Sodick Wire Cutting Machine



Swiss Agie Charmilles CNC



Makino CNC

Tooling Machine List

Equipment	Current Qty	New Qty in 2019
Swiss Agie Charmilles EDM	1 set	2 sets
Sodick EDM	6 sets	
Sodick Wire Cutting Machine	2 sets	2 sets
Brisk Wire Cutting Machine	5 sets	2 sets
Swiss Agie Charmilles CNC	1 set	3 sets
Beijing Carver CNC	2 sets	
Japan Makino CNC	1 set	
Tooling Capacity per Month	18	27



Facilities-Production



High Accurate Injection Molding Machine(14 pcs)



Vacuum Sintering Furnace(6 pcs)







Degreasing Furnace(3 pcs)



Gas hydraulic Machine(8pcs)



Facilities-Equipment List

Process		Equipment	Manufacturer	Current Qty	Qty by 2021	Note
Injection		Precision Injection Molding Machine	Japan Niessi	8	14	Manufacturer TBD.
Sintering		Degreasing Furnace	China SinterZone	4	6	No. 6 & No. 7 are Elinco Furnaces will be in production in Mar. 2016.
		Vacuum Sintering Furnace	China HIPE	6	8	Manufacturer TBD.
Re-striking		Gas hydraulic Machine	China Zunqi	8	TBD	Qty & Manufacturer TBD.

World Class Facilities-Test Equipment List

Equipment	Qty	Note
X ray spectrometer	1	
Roughness Tester	1	
Scale	4	Mettler Toledo
Laser particle size distribution analyzer	1	
Microscope	2	
Hardness Tester	1	
Melt flow rate tester	1	
CMM	1	1 Hexagon
Projector	1	
Salt Spray Test Chamber	1	
Image measuring instrument	6	2 OGP, 2 MVP
Non-destructive Detector	1	Saitek



PM FACTORY





Facilities-Production



Powder Punching Machine(12 pcs)



Continous Sintering Furnace(2 pcs)



Steam treatment furnace(2 pcs)



Sand blasting Machine(1pcs)

World Class Facilities-Test Equipment List

Equipment	Qty	Note
X ray spectrometer 3D	1	
Roughness Tester	1	
Scale	1	
Hardness Tester	2	
Salt Spray Test Chamber	1	
Image measuring instrument	2	
Non-destructive Detector	1	

DIE CASTING FACTORY



Mould Workshop



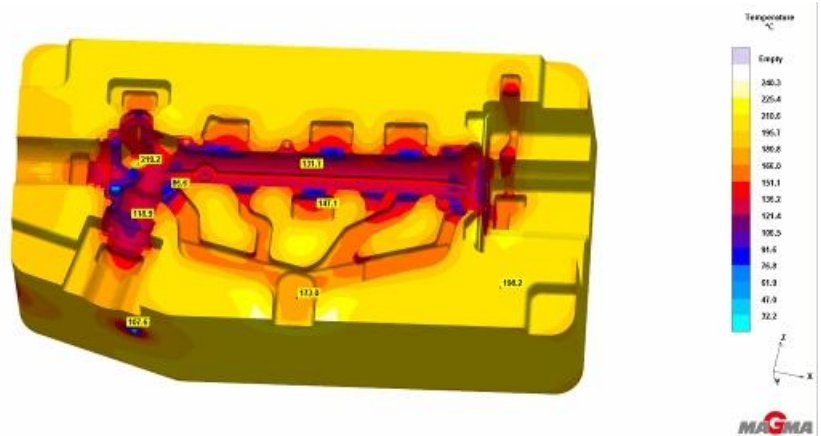
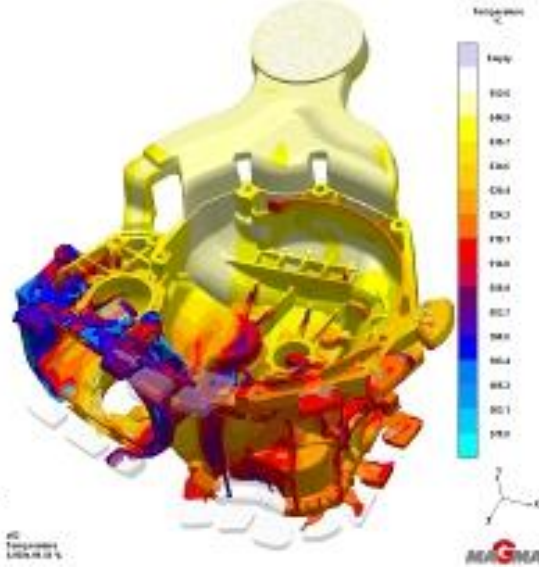
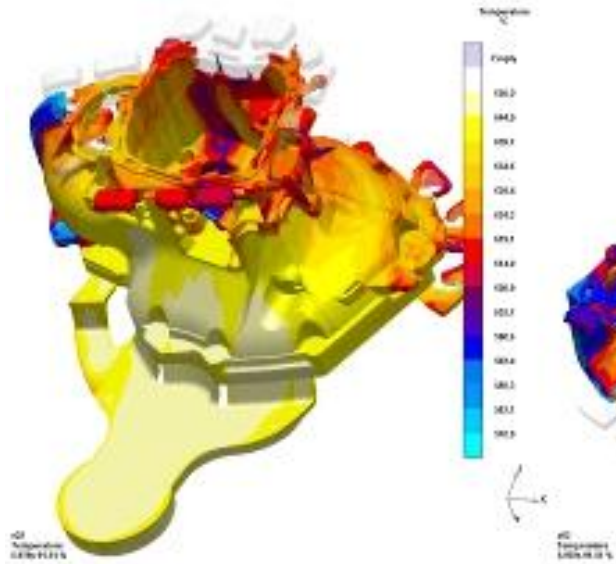





Facilities-Equipment List

Picture	Equipment	Manufacturer	Current Qty	Note
	Die casting machine	Japan TOYO/Toshiba China Haitian	10	200T---800T
	Holding Furnace	China Zhuwang	6	Qty & Manufacturer TBD.
	Melting Furnace	China Zhuwang	5	Qty & Manufacturer TBD.

World Class Facilities-Test Equipment List

Equipment	Qty	Note
X ray spectrometer	1	
CMM	1	ZEISS
Spectral Analysis	1	Bruker
Microscope	2	
Hardness Tester	1	
Melt flow rate tester	1	
Salt Spray Test Chamber	1	
Leakage Tester	7	



Content

- 01 **Company Overview**
- 02 **Factories view**
- 03 **Products**



Project: Metal CUP Fan

Technical Challenge:

- 33 vanes, 0.1mm thickness
- Vane deformation: 0.05mm
- Tolerance: $\pm 0.02\text{mm}$

Thin Metallic CPU Fan

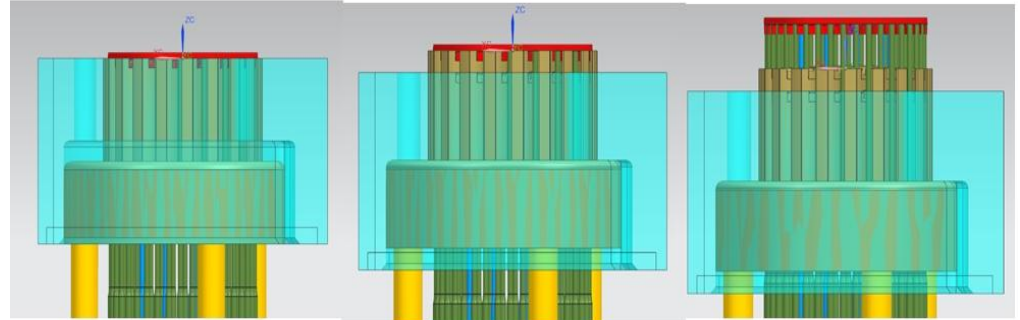

Technical Solutions :

- *Special binder formula to improve BASF material liquidity characteristic*
- *Creative ejection design*
- *Special mould gates design*

Mobile Phone Camera Metal Base



Huawei P30



Huawei P30 Pro





PM Products





Die Casting products

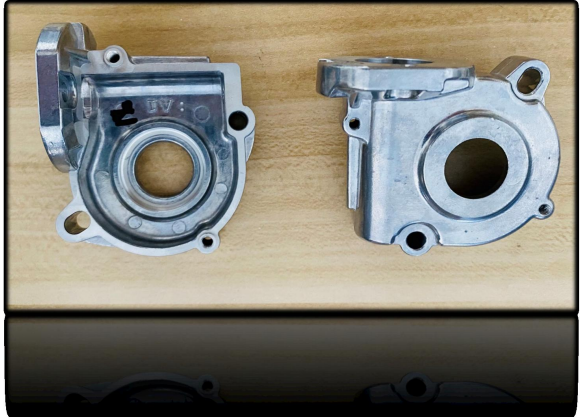
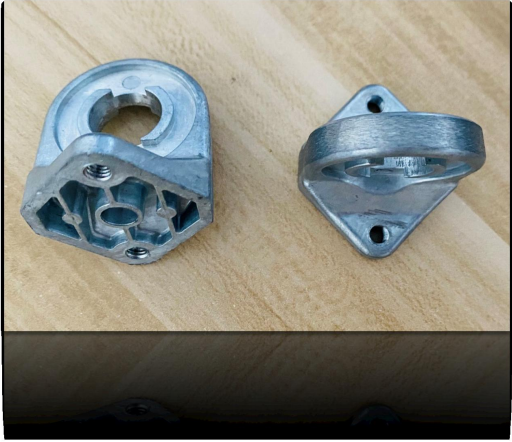

Service



Blow Customers trust us



Hoping next is you....

Thank you!



NINGBO JIEHUANG CHIYANG ELECTRONIC TECH CO.,LTD